

3A 150KHz 40V Buck DC/DC Converter With Constant Current Loop

XL4201

Features

- Wide 8V to 40V Input Voltage Range
- Output Adjustable from 1.25V to 37V
- Minimum Drop Out 0.3V
- Fixed 150KHz Switching Frequency
- Maximum 3A Switching Current
- Internal Optimize Power MOSFET
- Excellent line and load regulation
- With output constant current loop
- Built in thermal shutdown function
- Built in current limit function
- Built in input over voltage protection
- Recommend output power less than 13W
- SOP8-EP (Exposed PAD) package

Applications

- Car Charger
- Battery Charger
- LCD Monitor and LCD TV
- Portable instrument power supply
- Telecom / Networking Equipment
- Buck constant current driver
- Monitor LED Backlighting
- General purpose LED lighting

General Description

The XL4201 is a 150KHz fixed frequency PWM buck (step-down) DC/DC converter, capable of driving a 2.5A load with high efficiency, low ripple and excellent line and load regulation. Requiring a minimum number of external components, the regulator is simple to use and include internal frequency compensation and a fixed-frequency oscillator.

The PWM control circuit is able to adjust the duty ratio linearly from 0 to 100%. An enable function, an over current protection function is built inside. An internal compensation block is built in to minimize external component count.

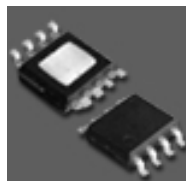

Figure1. Package Type of XL4201

Pin Configurations

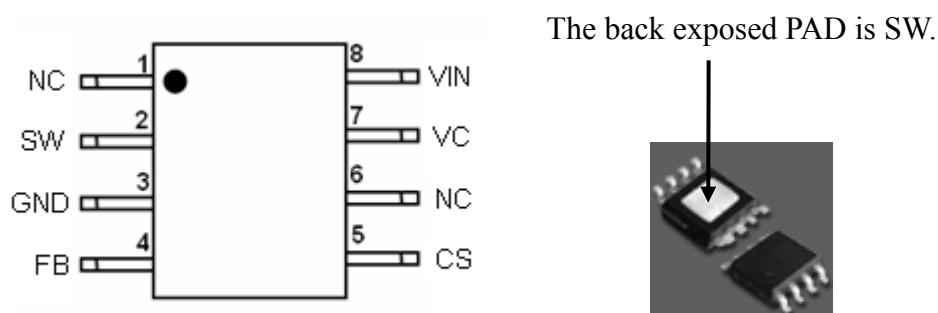

Figure2. Pin Configuration of XL4201 (Top View)

Table 1 Pin Description

Pin Number	Pin Name	Description
1, 6	NC	Not connected.
2	SW	Power Switch Output Pin (SW). Output is the switch node that supplies power to the output. (Note: Connected the back exposed PAD to SW.)
3	GND	Ground Pin.
4	FB	Feedback Pin (FB). Through an external resistor divider network, Feedback senses the output voltage and regulates it. The feedback threshold voltage is 1.25V.
5	CS	Output Current Sense Pin; ($I_{load} = 0.11V/R_{cs}$)
7	VC	Internal Voltage Regulator Bypass Capacity. In typical system application, The VC pin connect a 1uF capacity to VIN.
8	VIN	Supply Voltage Input Pin. XL4201 operates from a 8V to 40V DC voltage. Bypass Vin to GND with a suitably large capacitor to eliminate noise on the input.

Function Block

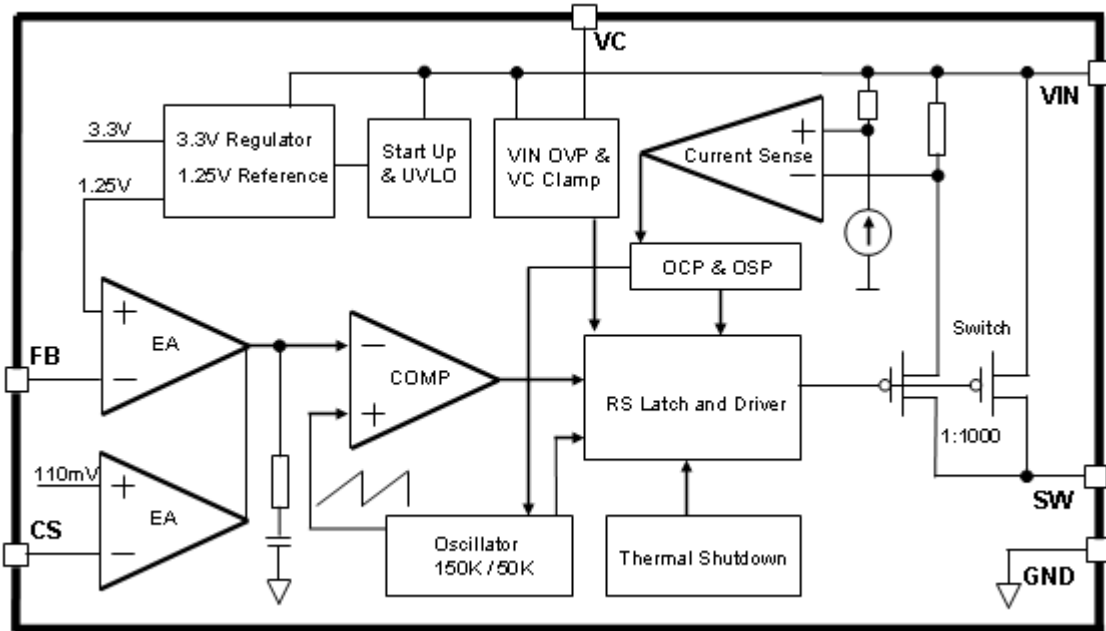

Figure3. Function Block Diagram of XL4201

Typical Application Circuit (Car Charger)

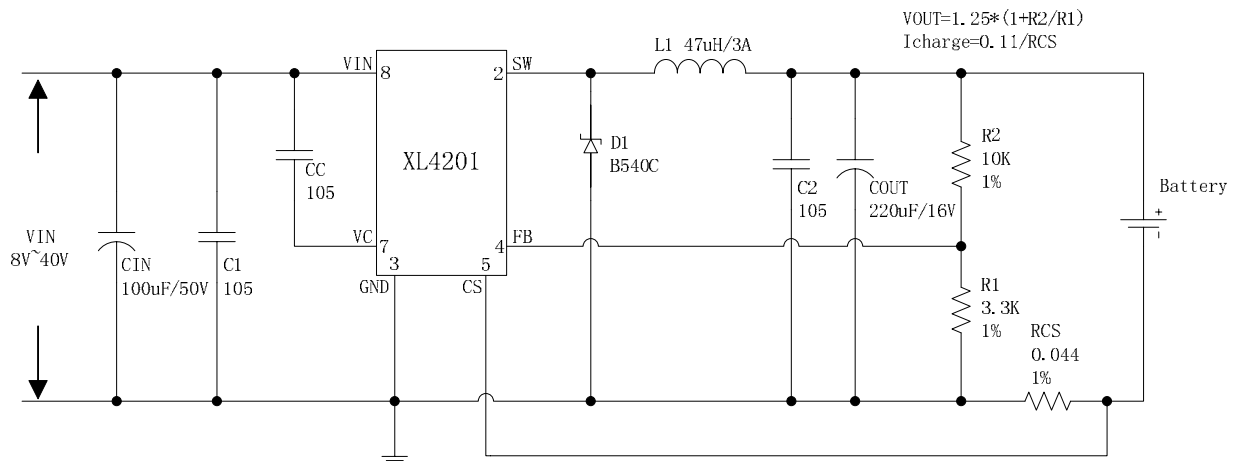

Figure4. XL4201 Typical Application Circuit (Li Battery Charger)

3A 150KHz 40V Buck DC/DC Converter With Constant Current Loop **XL4201**

Typical System Circuit(Buck LED Constant Current Driver)

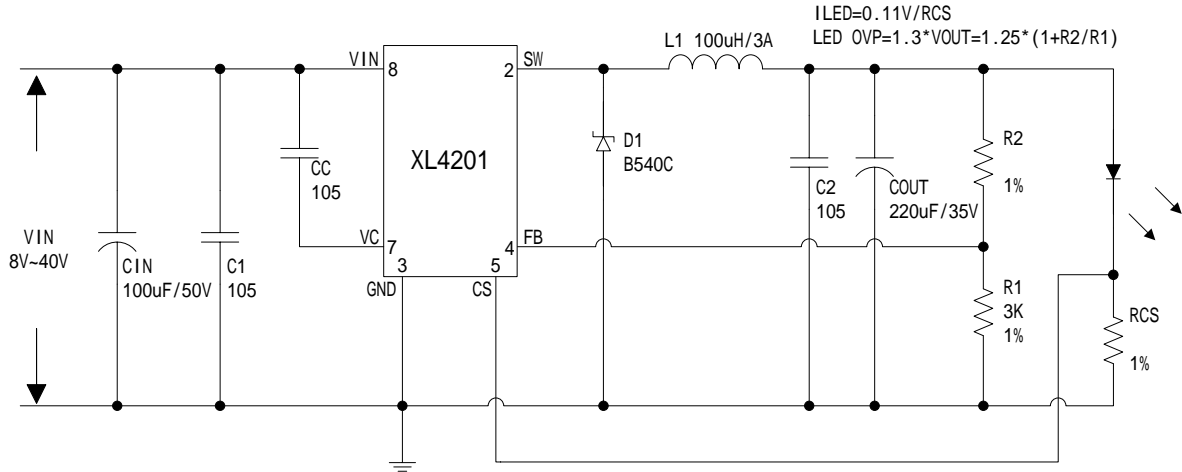

Figure5. XL4201 Typical Application Circuit(LED Constant Current Driver)

Ordering Information

Order Information	Marking ID	Package Type	Packing Type Supplied As
XL4201E1	XL4201E1	SOP8-EP	2500 Units on Tape & Reel

XLSEMI Pb-free products, as designated with “E1” suffix in the par number, are RoHS compliant.

Absolute Maximum Ratings (Note1)

Parameter	Symbol	Value	Unit
Input Voltage	V _{in}	-0.3 to 45	V
FB Pin Voltage	V _{FB}	-0.3 to V _{in}	V
SW Pin Voltage	V _{SW}	-0.3 to V _{in}	V
Power Dissipation	P _D	Internally limited	mW
Thermal Resistance (Junction to Ambient, No Heatsink, Free Air)	R _{JA}	60	°C/W
Maximum Junction Temperature	T _J	-40 to 150	°C
Operating Junction Temperature	T _J	-40 to 125	°C
Storage Temperature	T _{STG}	-65 to 150	°C
Lead Temperature (Soldering, 10 sec)	T _{LEAD}	260	°C
ESD (HBM)		>2000	V

Note1: Stresses greater than those listed under Maximum Ratings may cause permanent damage to the device. This is a stress rating only and functional operation of the device at these or any other conditions above those indicated in the operation is not implied. Exposure to absolute maximum rating conditions for extended periods may affect reliability.

3A 150KHz 40V Buck DC/DC Converter With Constant Current Loop	XL4201
---	--------

XL4201 Electrical Characteristics

T_a = 25 ; unless otherwise specified.

Symbol	Parameter	Test Condition	Min.	Typ.	Max.	Unit
<i>System parameters test circuit figure4</i>						
VFB	Feedback Voltage	V _{in} = 8V to 40V, V _{out} =5V I _{load} =0.2A to 2A	1.231	1.25	1.269	V
Efficiency	η	V _{in} =12V ,V _{out} =5V I _{out} =2.4A	-	89	-	%

Electrical Characteristics (DC Parameters)

V_{in} = 12V, GND=0V, V_{in} & GND parallel connect a 100uF/50V capacitor; I_{out}=500mA, T_a = 25 ; the others floating unless otherwise specified.

Parameters	Symbol	Test Condition	Min.	Typ.	Max.	Unit
VIN operation voltage	V _{in}		8		40	V
VIN UVLO	V _{uvlo}			5		V
VIN OVP	V _{ovp}			45		V
Quiescent Supply Current	I _q	V _{FB} =V _{in}		2	5	mA
Oscillator Frequency	F _{osc}		127	150	172	KHz
Switch Current Limit	I _L	V _{FB} =0		3.5		A
Output Power PMOS	R _{dson}	V _{FB} =0V, V _{in} =12V, I _{SW} =3A		75	100	mohm
Constant current sense Voltage	V _{CS}		104.5	110	115.5	mV

3A 150KHz 40V Buck DC/DC Converter With Constant Current Loop XL4201

Typical System Application (Car Charger)

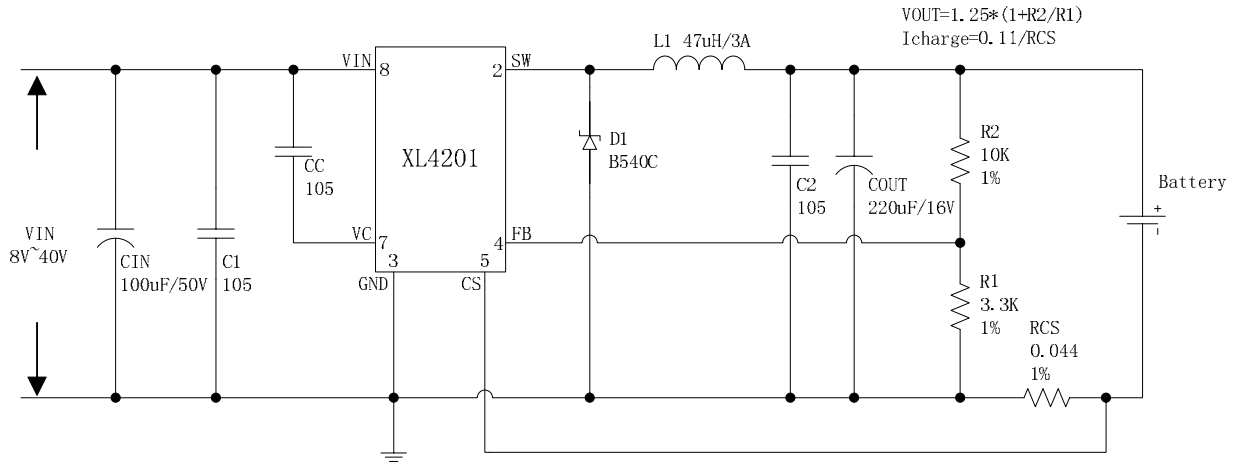

Figure6. XL4201 System Parameters Test Circuit (VIN=8V~40V, VOUT=5V/0.1A~2.5A)

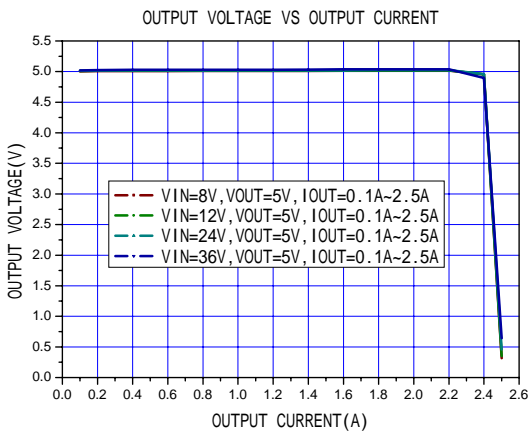

Figure7. Output Constant Current Curve

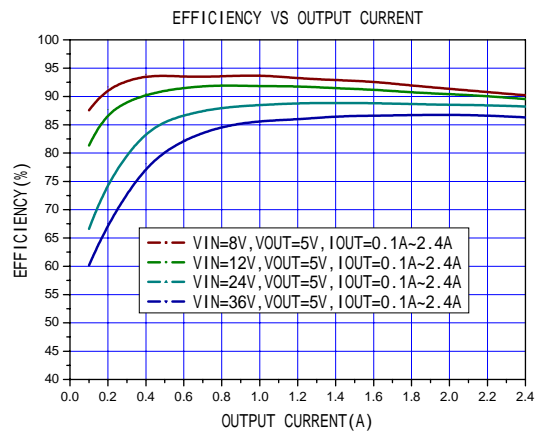

Figure8. Efficiency Curve

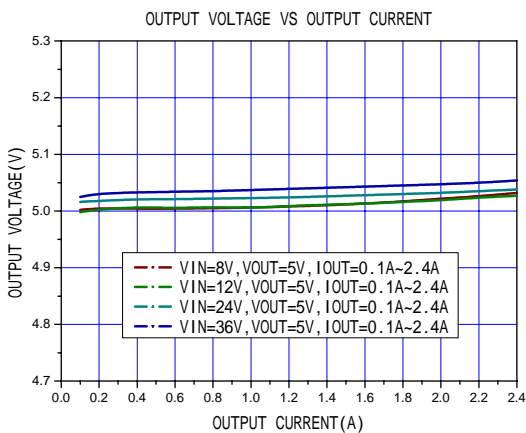

Figure9. Line&Load regulation Curve

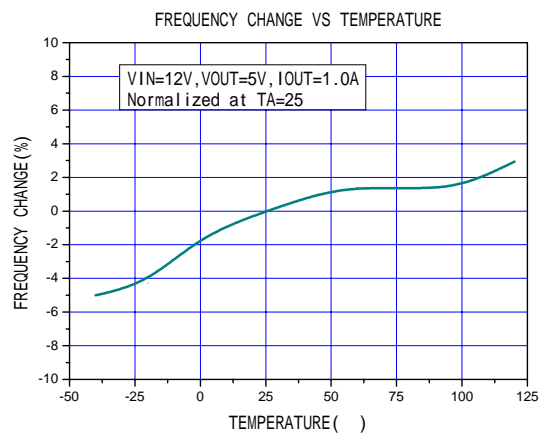
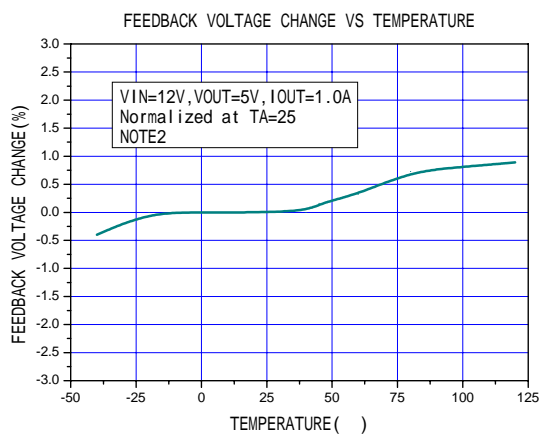

Figure10. Frequency change Curve



Note2: Internal temperature compensation circuitry is provided to compensation the PCB and external line loss in system application. When the junction temperature or the output power rise , the feedback voltage will be compensated. This function is provided to compensation the PCB and external line loss in system application.

Figure11. Feedback voltage change Curve

Typical System Application (Recommend output voltage safe work range in LED application)

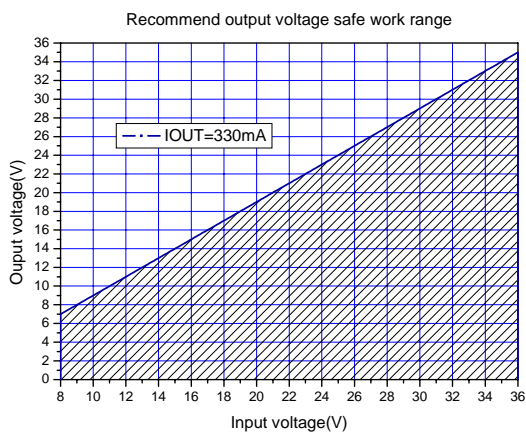

Figure12.Max output voltage(IOUT=330mA)

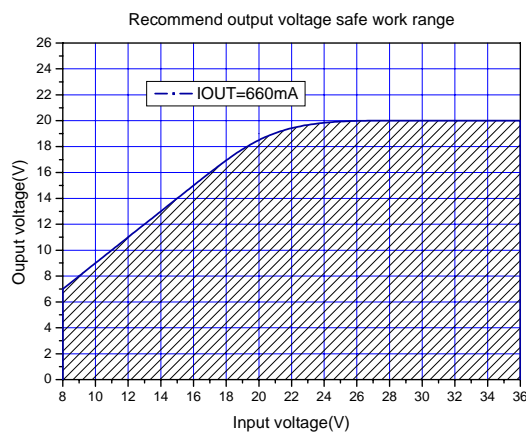

Figure13.Max output voltage(IOUT=660mA)

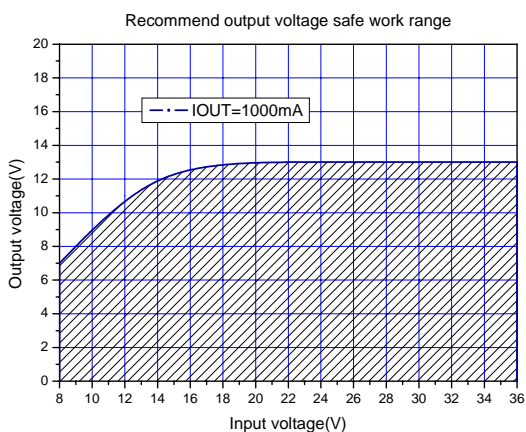

Figure14.Max output voltage(IOUT=1000mA)

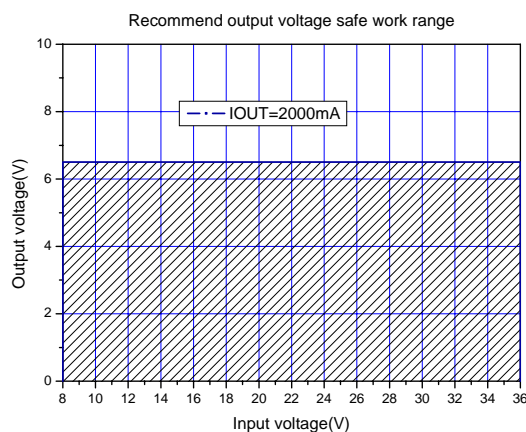

Figure15.Max output voltage(IOUT=2000mA)

Typical System Circuit(VIN=8V~36V,IOUT=330mA)

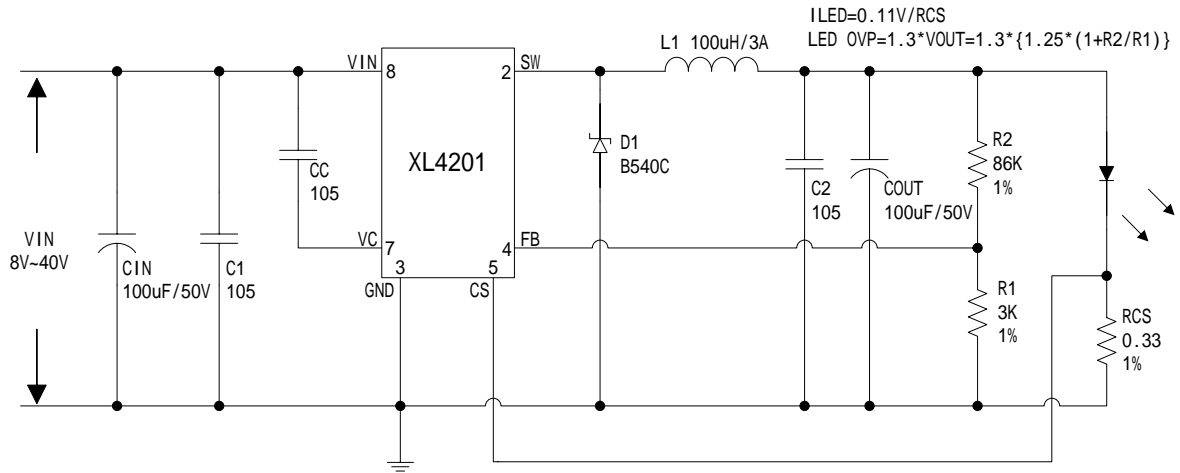

Figure16. XL4201 System Parameters Test Circuit (VIN=8V~40V,IOUT=330mA)

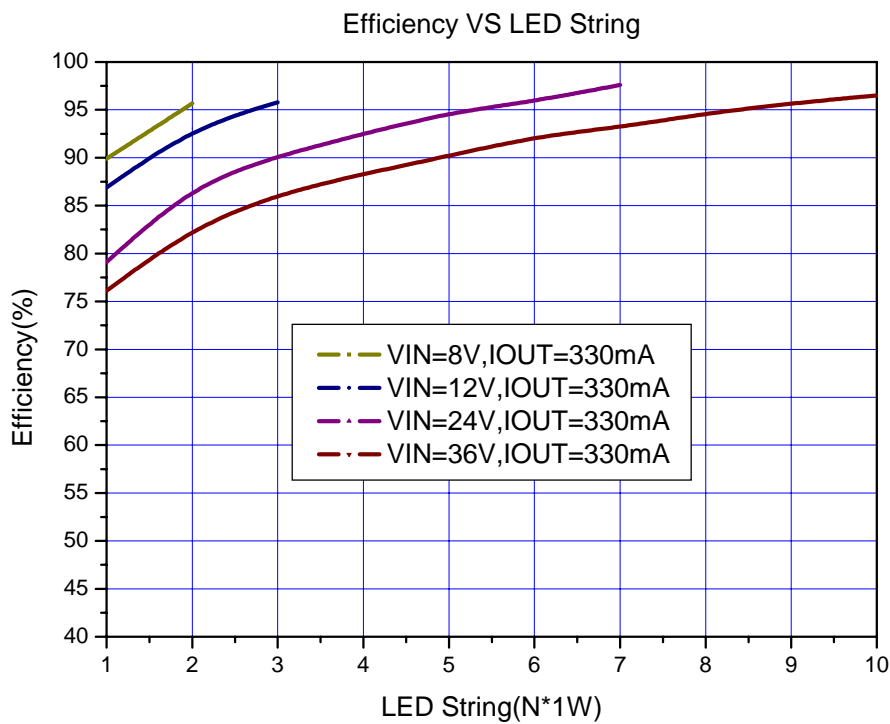

Figure17. XL4201 System Efficiency Curve (VIN=8V~40V,IOUT=330mA)

3A 150KHz 40V Buck DC/DC Converter With Constant Current Loop

XL4201

Typical System Circuit(VIN=8V~40V,IOUT=660mA)

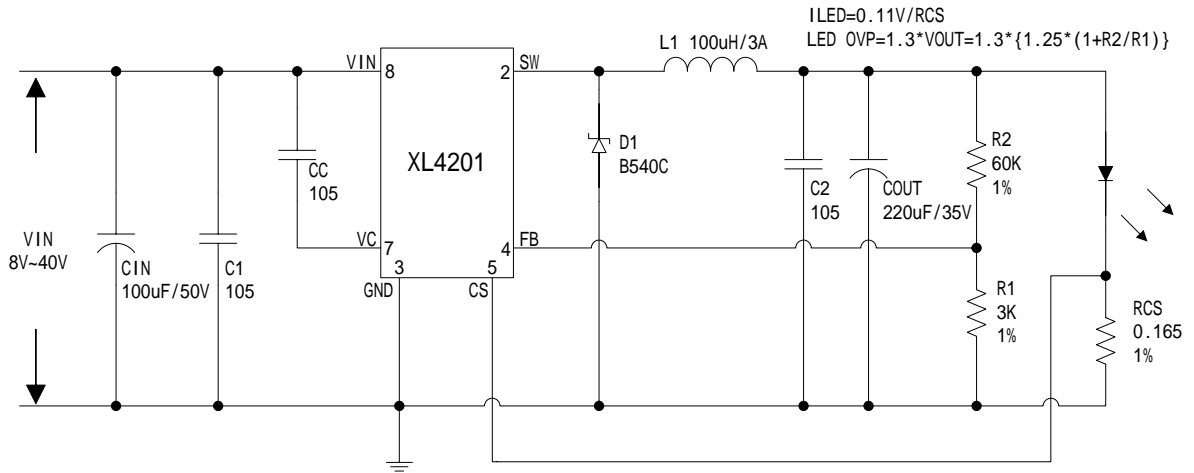

Figure18. XL4201 System Parameters Test Circuit (VIN=8V~40V,IOUT=660mA)

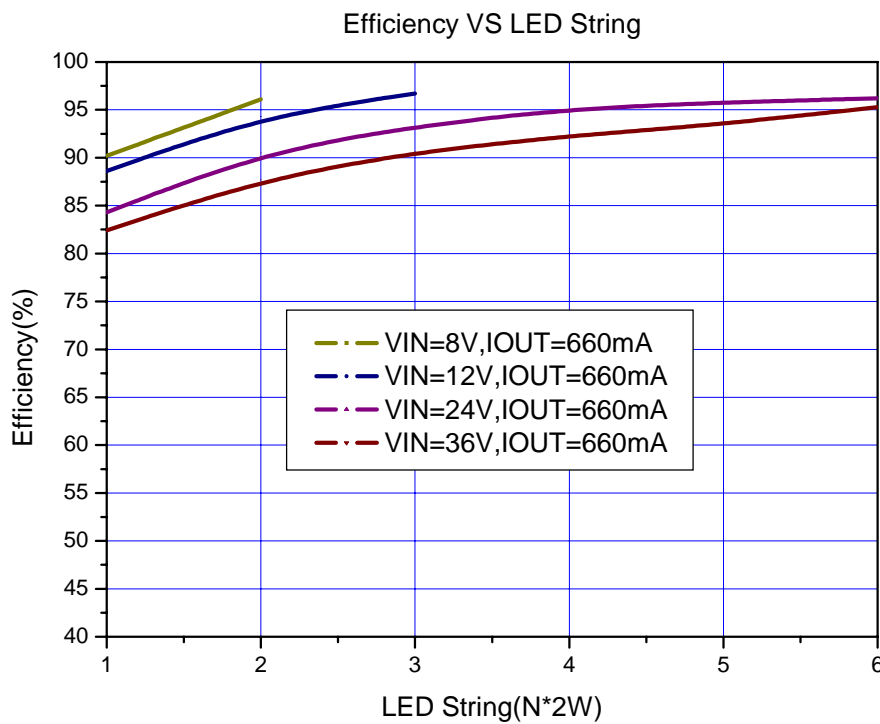

Figure19. XL4201 System Efficiency Curve (VIN=8V~40V,IOUT=660mA)

3A 150KHz 40V Buck DC/DC Converter With Constant Current Loop

XL4201

Typical System Circuit(VIN=8V~40V,IOUT=1000mA)

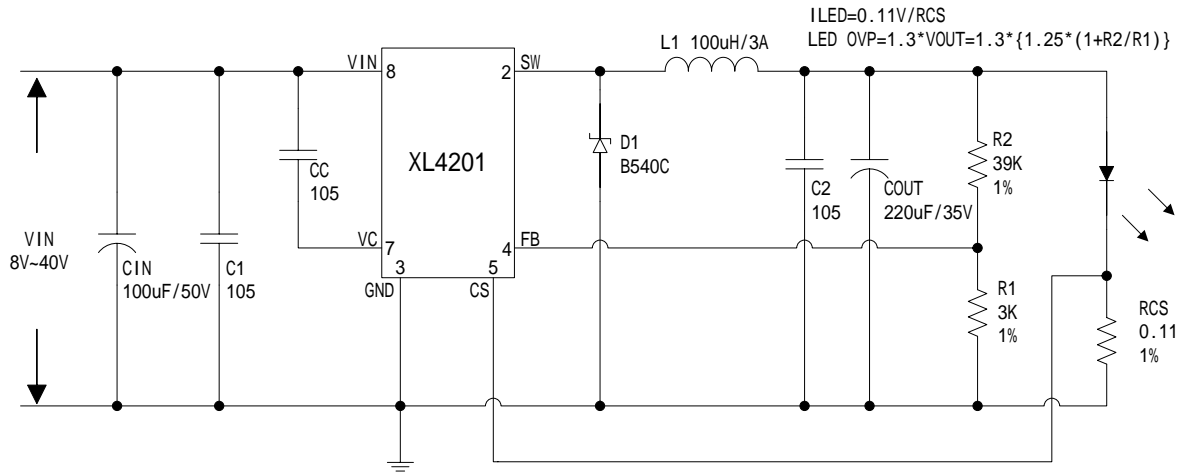

Figure20. XL4201 System Parameters Test Circuit (VIN=8V~40V,IOUT=1000mA)

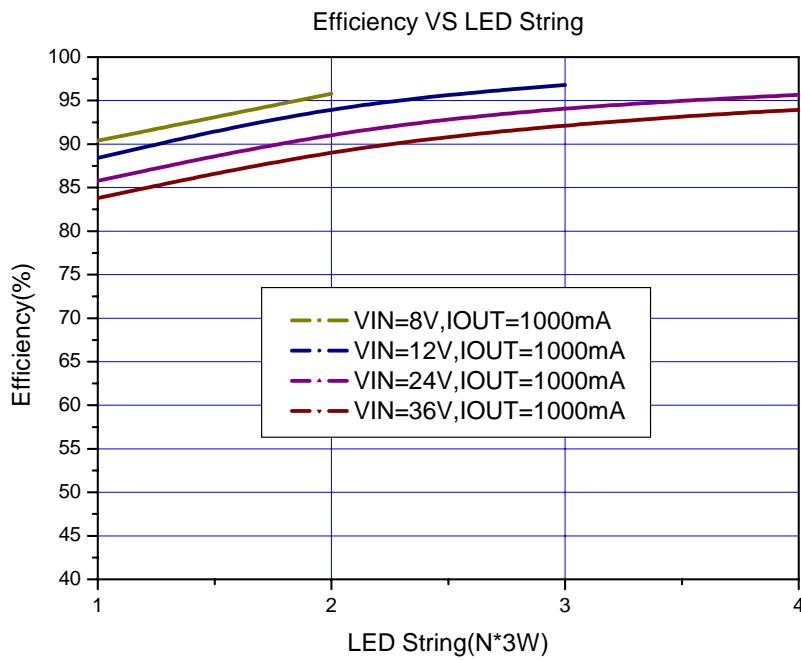

Figure21. XL4201 System Efficiency Curve (VIN=8V~40V,IOUT=1000mA)

3A 150KHz 40V Buck DC/DC Converter With Constant Current Loop

XL4201

Typical System Circuit(PWM Dimming)

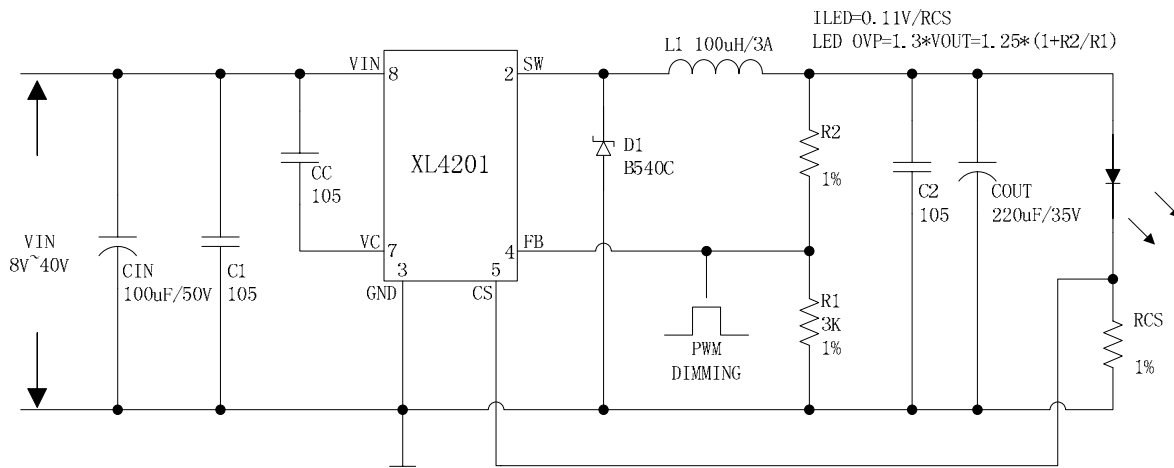
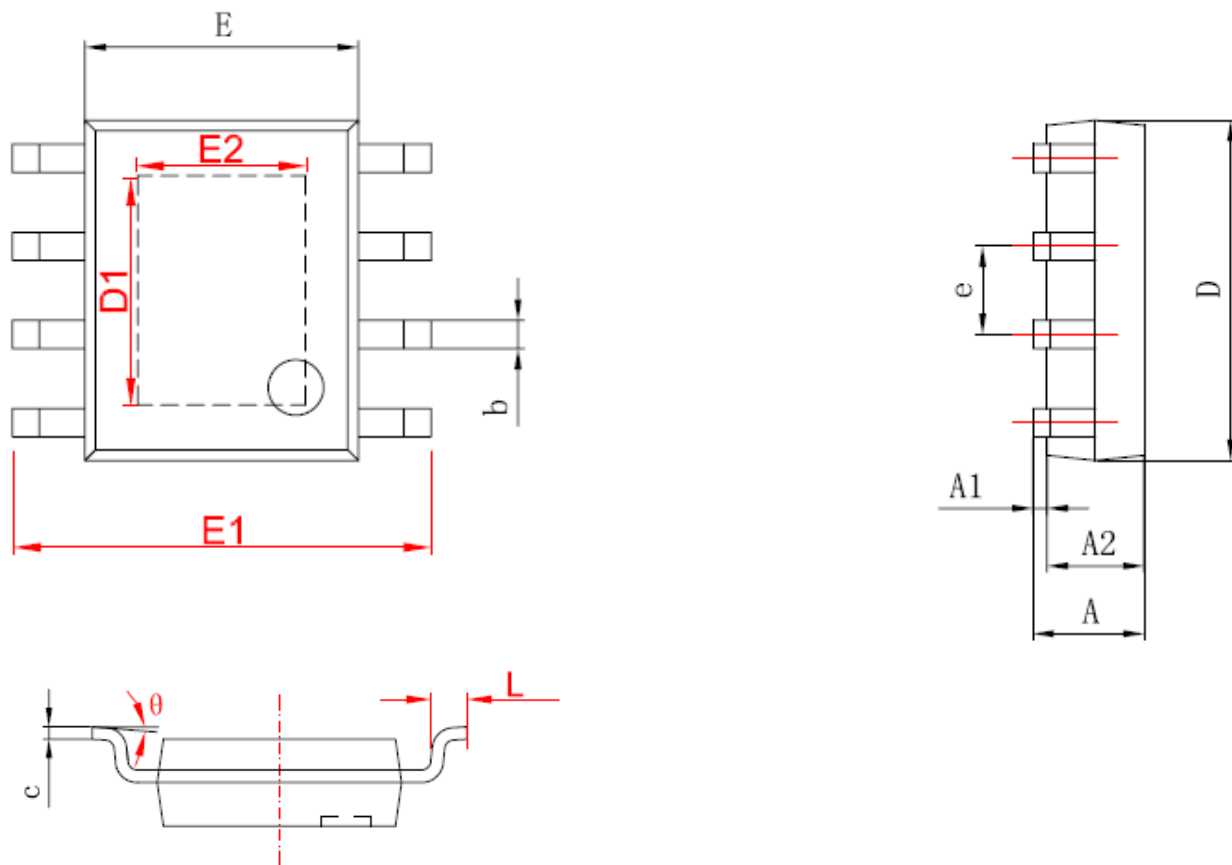

Figure22. XL4201 System Parameters Test Circuit

Schottky Diode Selection Table

Current	Surface Mount	Through Hole	VR (The same as system maximum input voltage)				
			20V	30V	40V	50V	60V
1A			1N5817	1N5818	1N5819		
			1N5820	1N5821	1N5822		
3A			MBR320	MBR330	MBR340	MBR350	MBR360
			SK32	SK33	SK34	SK35	SK36
				30WQ03	30WQ04	30WQ05	
				31DQ03	31DQ04	31DQ05	
			SR302	SR303	SR304	SR305	SR306
5A			1N5823	1N5824	1N5825		
			SR502	SR503	SR504	SR505	SR506
			SB520	SB530	SB540	SB550	SB560
			SK52	SK53	SK54	SK55	SK56
				50WQ03	50WQ04	50WQ05	

Package Information (SOP8-EP)



字符	Dimensions In Millimeters		Dimensions In Inches	
	Min	Max	Min	Max
A	1.350	1.750	0.053	0.069
A1	0.050	0.150	0.004	0.010
A2	1.350	1.550	0.053	0.061
b	0.330	0.510	0.013	0.020
c	0.170	0.250	0.006	0.010
D	4.700	5.100	0.185	0.200
D1	3.202	3.402	0.126	0.134
E	3.800	4.000	0.150	0.157
E1	5.800	6.200	0.228	0.244
E2	2.313	2.513	0.091	0.099
e	1.270 (BSC)		0.050 (BSC)	
L	0.400	1.270	0.016	0.050
theta	0°	8°	0°	8°

3A 150KHz 40V Buck DC/DC Converter With Constant Current Loop	XL4201
---	--------

Important Notice

XLSEMI reserve the right to make modifications, enhancements, improvements, corrections or other changes without notice at any time. XLSEMI does not assume any liability arising out of the application or use of any product described herein; neither does it convey any license under its patent rights, nor the rights of others. XLSEMI assumes no liability for applications assistance or the design of Buyers' products. Buyers are responsible for their products and applications using XLSEMI components. To minimize the risks associated with Buyers' products and applications, Buyers should provide adequate design and operating safeguards. XLSEMI warrants performance of its products to the specifications applicable at the time of sale, in accordance with the warranty in XLSEMI's terms and conditions of sale of semiconductor products. Testing and other quality control techniques are used to the extent XLSEMI deems necessary to support this warranty. Except where mandated by applicable law, testing of all parameters of each component is not necessarily performed.

For the latest product information, go to www.xlsemi.com.